

Statement:

EML-M/G micro surface water-proof Electromagnetic Locks are manufactured under GEM's ISO 9001 Certified Quality Management Program environment back its product quality, performance and commitment to customer satisfaction.

The fail-safe Electromagnetic Lock design with no mechanical bolt and depending on the powerful magnetic force to secure and release the door are suitable for use in areas which required security access control or egress such as Cabinet, Drawers, Gun safes, Machine, Equipment, Housings...etc.

The Electromagnetic Locks are totally sealed in an epoxy filled stainless steel case for water-resistant and vandal-resistant purpose. A threaded conduit fitting ensures weather resistant protection of the wiring therefore it is ideal for indoor and outdoor applications, even in severe weather.

The model offers up to 300 pounds holding force with 12V DC power input (24V DC or 12/24V DC dual voltage available by special order) and with the full range of optional brackets. It is the best choice for electronic security industry and system integrators.



Regular Installation

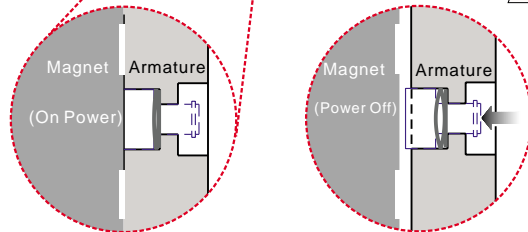
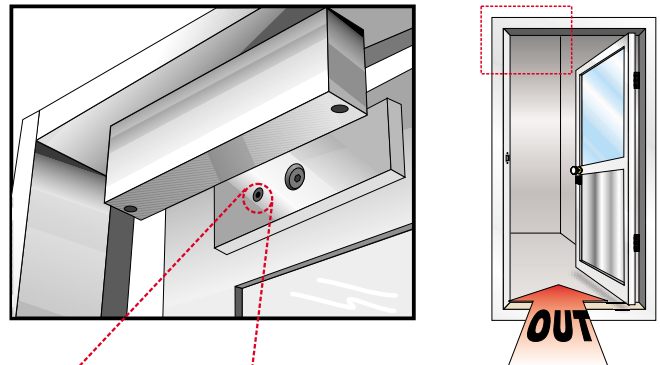

Unique Anti-Residual design

When there is no power, there will be no holding force, and the push-off button inside the Armature Plate will pop out immediately to release the Electromagnetic Lock and the Armature Plate. The instant release circuit function will prevent residual magnetism between Electromagnetic Lock and the Armature Plate.

Specifications:

- Voltage Tolerance: $\pm 15\%$
- Current Draw: 300mA@12Vdc (at temperature 20°C)
- Operating Temperature: -10~55°C (14~131°F)
- Humidity: 0~95% non-condensing.
- Lock's surface Temperature (when the power is on): \leq current temperature +20°C
- Holding Force: Up to 300 lbs (136 Kg)
- Dimensions:
 - Magnet:(L) 170, (W) 32, (D) 24 mm
 - Armature Plate:(L) 152, (W) 32, (D) 10 mm
- Special Finishes for magnet and armature plate: Zinc
- Epoxy Potting Compound: E87252 (S), UL94V-0
- Weight (Approx.) : 1.5 Kg

Warranty:

GEM Electromagnetic Locks are warranted against defects in material and workmanship while used in normal service for a period of 5 years from the date of sale to the original customer.

Disclaimer:

The information and specifications printed in this manual are current at the time of publication. The GEM policy is one of continual development and improvement; therefore GEM reserves the right to change specifications without notice.

Distributed by

Nidac Security Pty. Ltd.
 2 Cromwell St, Burwood, Victoria, Australia, 3125
 TEL: 61-3-9808 6244 FAX: 61-3-9808 9335
 E-mail: sales@nidac.com Website: www.nidac.com



Optional Brackets:

Identify the door swinging direction and inspect the door frame header to determine if bracket is required. A L- brackets, LZ- brackets may be required for the electromagnet depending on the frame header and swinging direction.

With L-bracket for narrow door frames

When "A" < 38 mm ,must installed with "L" brackets.

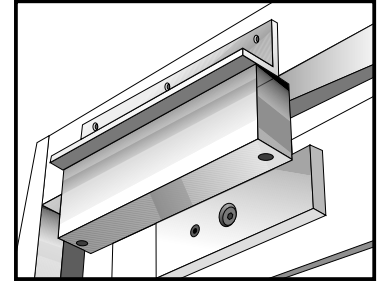
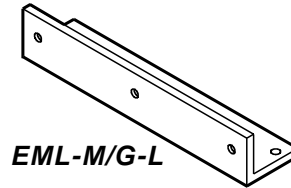
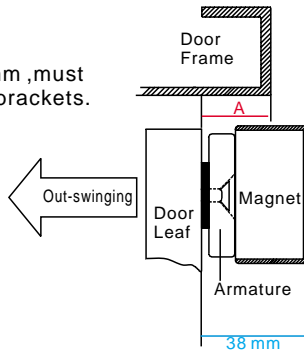

Distributed by

Nidac Security Pty. Ltd.
2 Cromwell St, Burwood, Victoria, Australia, 3125
TEL: 61-3-9808 6244 FAX: 61-3-9808 9335
E-mail: sales@nidac.com Website: www.nidac.com

Copyright all rights reserved
DM-CA-2004-10003S Ver. A Publish:2004.11.22

The products are manufactured under an ISO 9001 Certified Quality Management Program environment back its product quality, performance and commitment to customer satisfaction.

