



**PREMIUM  
QUALITY**

# POWER SPORTS

## ABSORBED GLASS MAT TECHNOLOGY

Advanced  
generation  
technology for  
performance  
and life!



**Ideal for ATVs,  
Motorcycles,  
Personal Watercraft  
& Snowmobiles**

The **Deka Power Sports AGM Battery** was designed for more than performance, it was designed for the enthusiast. Completely spillproof and leakproof; frequent replacement and high maintenance are over! The absorbed glass mat (AGM) technology increases power while improving rider and environmental safety. The key to this technology is the highly porous microfiber separators which completely absorb and trap the electrolyte. Molded top and side connection terminals provide versatility, increased strength and durability. The **Deka Power Sports AGM Battery** provides the most advanced power and value in the industry, so your customers can enjoy their leisure time, worry free.

### WORRY FREE...

- No Vent tube
- No acid leaks to cause terminal corrosion
- Withstands damaging effects of vibration
- Environmentally friendly, 100% recyclable

### MAINTENANCE FREE...

- No Filling
- No Activation
- Eliminates low water levels
- Low discharge rates for off season storage



QUALITY SYSTEM  
CERTIFIED TO  
**ISO 9001**

**Specifically Engineered for Demanding Power Sports Use!**



# POWER SPORTS

## ABSORBED GLASS MAT TECHNOLOGY

Premium quality, specially designed Absorbed Glass Mat batteries are manufactured under strict quality controls to assure superior performance and long life. The AGM design allows easy installation without the worry of acid spills and damage to equipment.

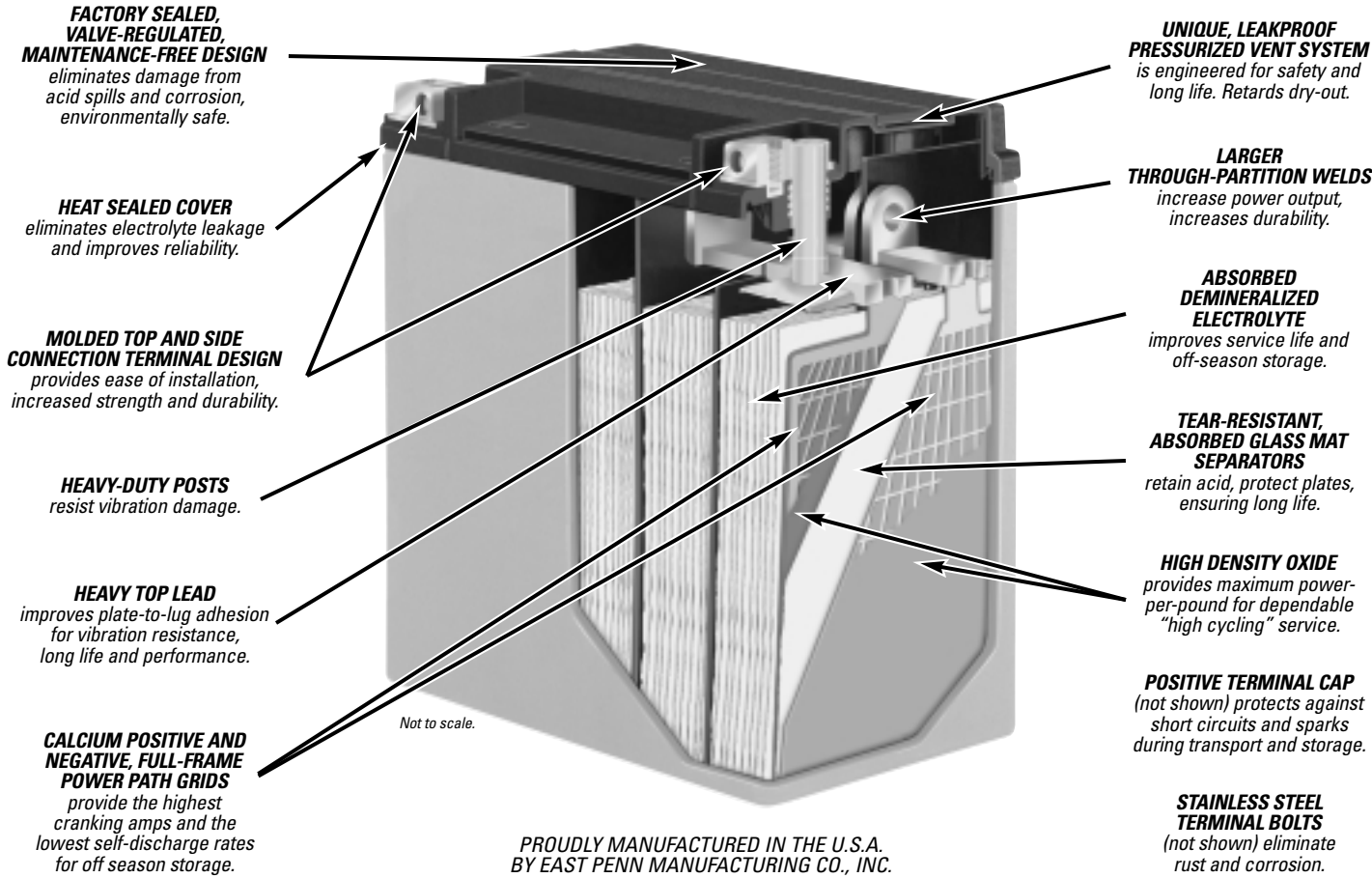

**Deka** EAST PENN manufacturing co., inc.

Lyon Station, PA 19536-0147 • Phone: 610-682-6361 • Fax: 610-682-4781

**Order Department Hotline: 610-682-4231**

WWW: <http://www.eastpenn-deka.com>

E-mail: [eastpenn@eastpenn-deka.com](mailto:eastpenn@eastpenn-deka.com)

E.P.M. Form No. 0278

© 2001 by EPM Printed in U.S.A.

No part of this document may be copied or reproduced, electronically or mechanically, without written permission from the company.